

EMISSION SUB SYSTEMS - Catalytic Converter

Catalytic Converter

A Three-Way Catalytic Converter is used to cause a desirable chemical reaction to take place in the exhaust flow

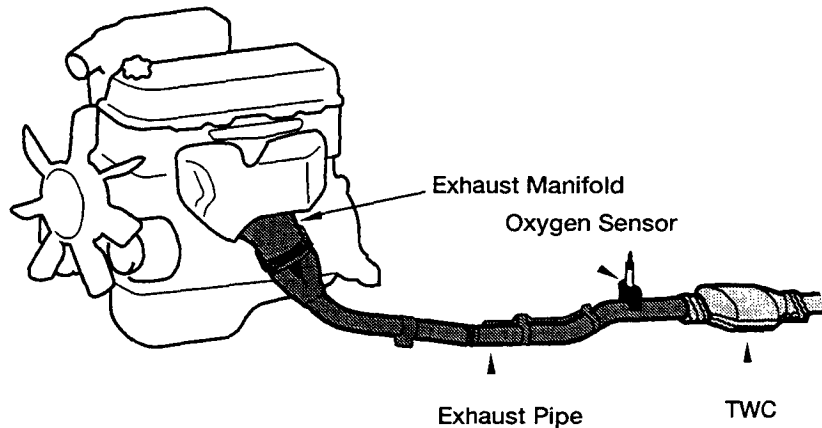

Catalytic Converter

Regardless of how perfect the engine is operating, there will always be some harmful by-products of combustion. This is what necessitates the use of a Three-Way Catalytic (TWC) Converter. This device is located in-line with the exhaust system and is used to cause a desirable chemical reaction to take place in the exhaust flow.

Essentially, the catalytic converter is used to complete the oxidation process for hydrocarbon (HC) and carbon monoxide (CO), in addition to reducing oxides of nitrogen (NOx) back to simple nitrogen and carbon dioxide.

Monolithic TWC

Late model Toyota vehicles are equipped with monolith TWC that use a honeycomb

Outer Shell

Wire Net



TWC Construction

Two different types of Three-Way Catalytic Converters have been used on fuel injected Toyota vehicles. Some early EFI vehicles used a **pelletized** TWC that was constructed of catalyst coated pellets tightly packed in a sealed shell, while later model vehicles are equipped with a monolith type TWC that uses a honeycomb shaped catalyst element. While both types operate similarly, the **monolith** design creates less exhaust backpressure, while providing ample surface area to efficiently convert feed gases.

EMISSION SUB SYSTEMS - Catalytic Converter

The Three-Way Catalyst, which is responsible for performing the actual feed gas conversion, is created by coating the internal converter substrate with the following key materials:

- **Platinum/Palladium;** Oxidizing catalysts for HC and CO
- **Rhodium;** Reducing catalyst for NOx
- **Cerium;** Promotes oxygen storage to improve oxidation efficiency The diagram below shows the chemical reaction that takes place inside the converter.

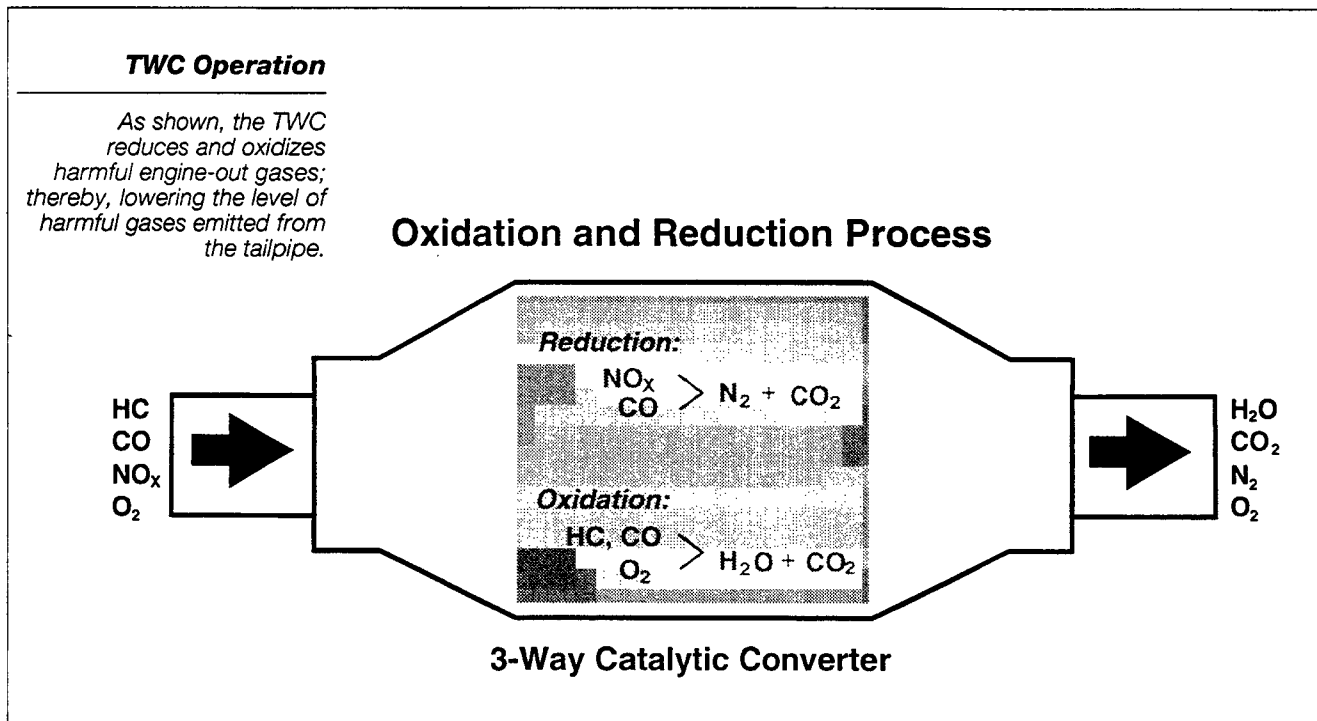

TWC Operation

As engine exhaust gases flow through the converter passageways, they contact the coated surface which initiate the catalytic process. As exhaust and catalyst temperatures rise, the following reaction occurs:

- Oxides of nitrogen (NOx) are **reduced** into simple nitrogen (N₂) and carbon dioxide (CO₂)
- Hydrocarbons (HC) and carbon monoxide (CO) are **oxidized** to create water (H₂O) and carbon dioxide (CO₂)

EMISSION SUB SYSTEMS - Catalytic Converter

Catalyst operating efficiency is greatly affected by two factors; operating temperature and feed gas composition. The catalyst begins to operate at around 550° F.; however, efficient purification does not take place until the catalyst reaches at least 750° F. Also, the converter feed gasses (engine-out exhaust gases) must alternate rapidly between high CO content, to reduce NO_x emissions, and high O₂ content, to oxidize HC and CO emissions.

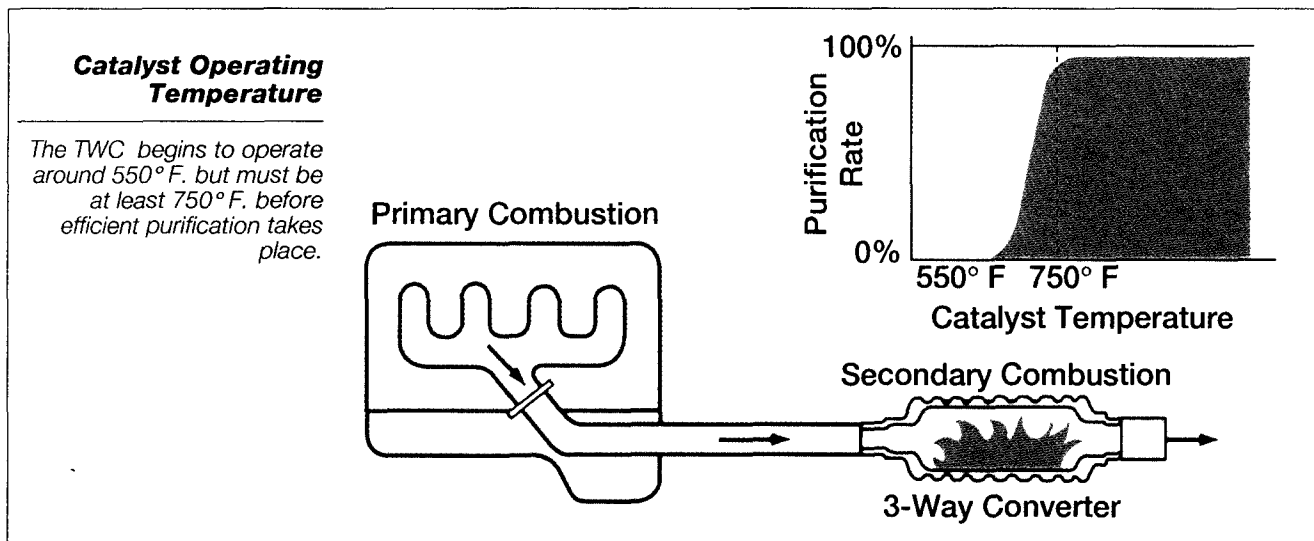

Effects of Closed Loop Control on TWC Operation

To ensure that the catalytic converter has the feed gas composition it needs, the closed loop control system is designed to rapidly alternate the air/fuel ratio slightly rich, then slightly lean of stoichiometry. By doing this, the carbon monoxide and oxygen content of the exhaust gas also alternates with the air/fuel ratio. In short, the converter works as follows:

- **When the A/F ratio is leaner than stoichiometry**, the oxygen content of the exhaust stream rises and the carbon monoxide content falls. This provides a high efficiency operating environment for the oxidizing catalysts (platinum and palladium). During this lean cycle, the catalyst (by using cerium) also stores excess oxygen which will be released to promote better oxidation during the rich cycle.
- **When the A/F ratio is richer than stoichiometry**, the carbon monoxide content of the exhaust rises and the oxygen content falls. This provides a high efficiency operating environment for the reducing catalyst (rhodium). The oxidizing catalyst maintains its efficiency as stored oxygen is released.

EMISSION SUB SYSTEMS - Catalytic Converter

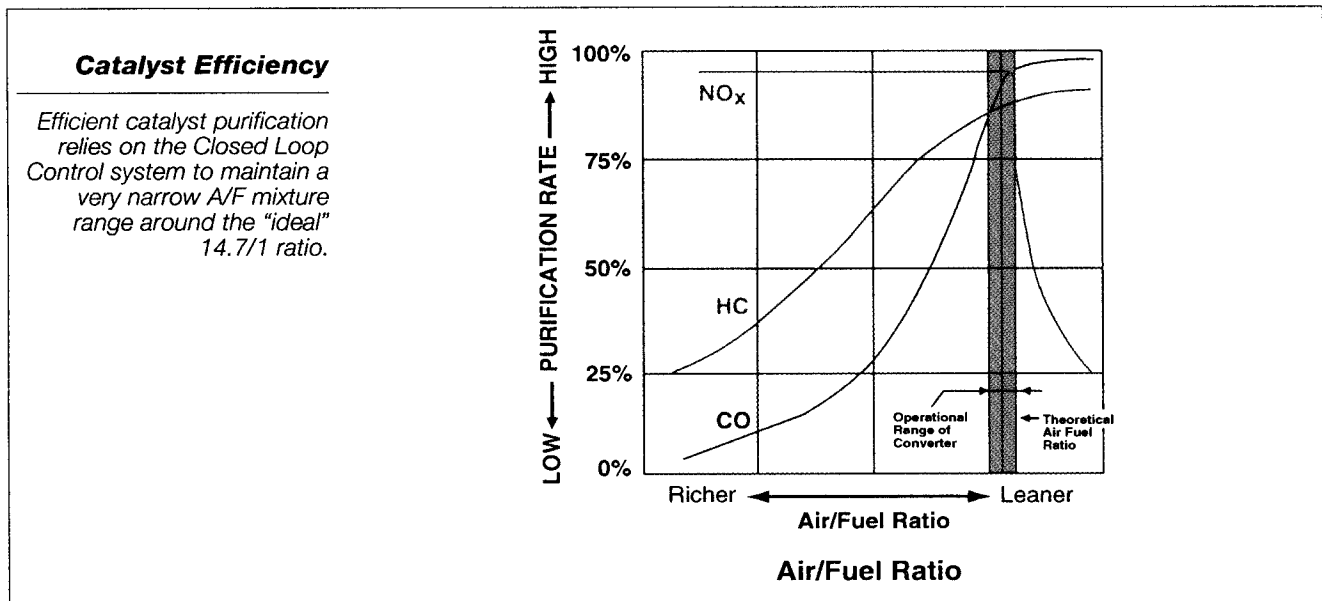

As mentioned in the beginning of this section, precise closed loop control relies on accurate feedback information provided from the exhaust oxygen sensor. The sensor acts like a switch as the air/fuel ratio passes through stoichiometry.

Closed loop fuel control effectively satisfies the three way catalyst's requirement for ample supplies of both carbon monoxide and oxygen. Generally speaking, if the closed loop control system is functioning normally, and fuel trim is relatively neutral, you can be assured that the air induction and fuel delivery sub-systems are also operating normally. If the closed loop control system is not working properly, the impact on catalytic converter efficiency, and ultimately emissions, can be significant.

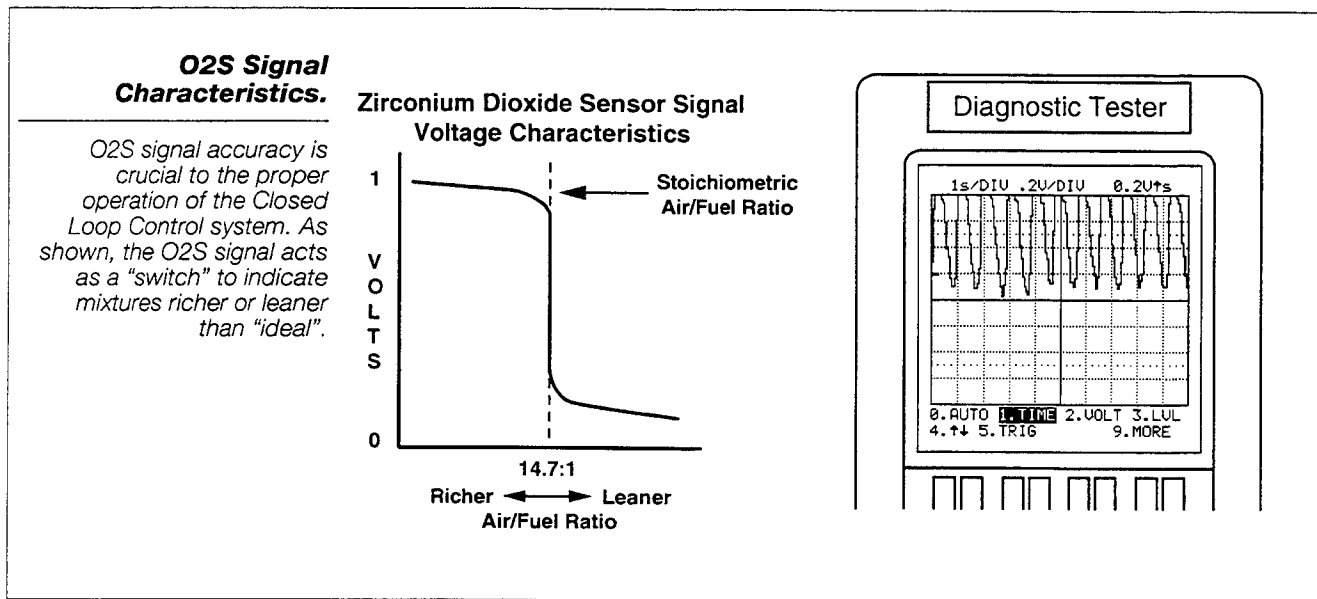

Effects of Oxygen Sensor Degradation

Since the oxygen sensor is the heart of the closed loop control system, proper operation is critical to efficient emission control. There are several factors which can cause the oxygen sensor signal to degrade and they include the following:

- **Silicon contamination** from chemical additives, some RTV sealers, and contaminated fuel.
- **Lead contamination** can be found in certain additives and leaded motor fuels.
- **Carbon contamination** is caused by excessive short trip driving and/or malfunctions resulting in an excessively rich mixture.

The effects of sensor degradation can range from a subtle shift in air/fuel ratio to a totally inoperative closed loop system. With respect to driveability and emissions diagnosis, a silicon contaminated sensor will cause the most trouble.

When silicon burns in the combustion chamber, it causes a silicon dioxide glaze to form on the oxygen sensor. This glaze causes the sensor to become sluggish when switching from rich to lean, and in some cases, increases the sensor minimum voltage on the lean switch. This causes the fuel system to spend excessive time delivering a lean mixture.

EMISSION SUB SYSTEMS - Catalytic Converter

Rich Biased O2S Signal

The O2S signal displayed is considered rich biased (does not fall below 400mv on the lean swing). This causes the Closed Loop Control system to shift A/F mixture lean, resulting in a decrease to TWC reduction efficiency.

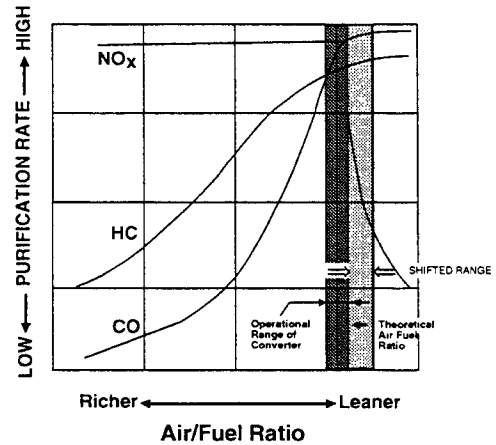
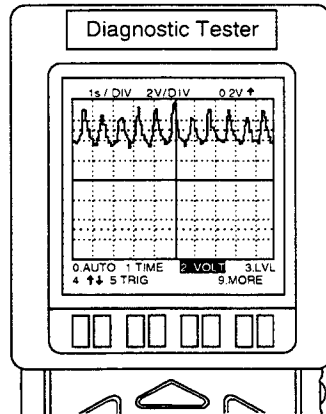

It is often difficult to identify a sensor which is marginally degraded, and in many cases, vehicle driveability may not be effected significantly. With the advent of IM240 emissions testing, however, marginal sensor degradation may cause some vehicles to fail the NOx portion of the loaded mode test.

The impact of a slightly lean mixture has a dual effect on emissions. A leaner mixture means higher combustion temperatures so more NOx is produced during combustion. Additionally, because less carbon monoxide is available in catalyst feed gas, the reducing catalyst efficiency falls off dramatically. The end result is a vehicle which may fail an IM240 test for excessive NOx.

Rich > Lean Switch Time

When rich to lean switch time becomes excessive, the air/fuel mixture gets leaner. There is no standard for R > L switch time; however, good sensors (like the one displayed) will typically switch from 700 mv to 200 mv in less than 350 milliseconds.

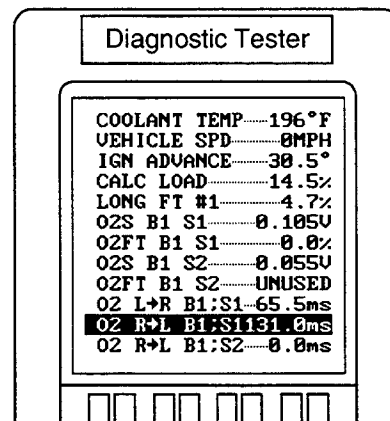
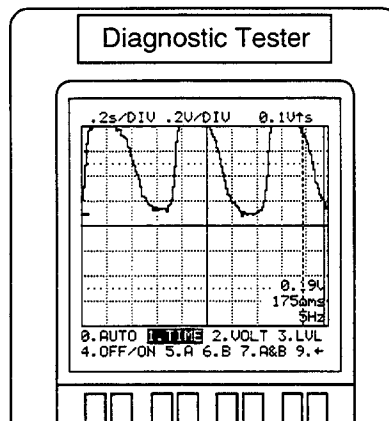

EMISSION SUB SYSTEMS - Catalytic Converter

As previously mentioned, the O₂S signal voltage must fluctuate above and below 0.45 volts at least 8 times in 10 seconds at 2500 rpm with the engine at operating temperature. During the rich swing, voltage should exceed 550 mv and during the lean swing should fall below 400 mv. O₂S signal checks can be made using the Autoprobe feature of the Diagnostic Tester, digital multimeter, or O₂S/RPM check using the Diagnostic Tester. Refer back to the oxygen sensor tests in the closed loop control section for specific test procedures.

Effects of TWC Degradation

Now that we understand the effects of O₂S degradation on catalyst efficiency, let's look at the effects of a catalytic converter failure. Keep in mind, there are many different factors that can cause its demise.

- **Poor engine performance** as a result of a restricted converter. Symptoms of a restricted converter include; loss of power at higher engine speeds, hard to start, poor acceleration and fuel economy.
- **A red hot converter** indicates exposure to raw fuel causing the substrate to overheat. This symptom is usually caused by an excessive rich air/fuel mixture or engine misfire. If the problem is not corrected, the substrate may melt, resulting in a restricted converter.
- **Rotten egg odor** results from excessive hydrogen sulfide production and is typically caused by high fuel sulfur content or air/fuel mixture imbalance. If the problem is severe and not corrected, converter meltdown and/or restriction may result.
- **IM emission test failure** may occur if catalyst performance falls below its designed efficiency level. Perform additional tests to confirm that the problem is in fact converter efficiency and not the result of engine or emission sub-system failure. ***Never use an emission test failure as the only factor in replacing a catalytic converter! If you do, you may not be fixing the actual cause of the emission failure.***

Causes of TWC Contamination

Like the oxygen sensor, the most common cause of catalytic converter failure is contamination. Examples of converter contaminants include:

- **Overly rich air/fuel mixtures** will cause the converter to overheat causing substrate meltdown.
- **Leaded fuels**, even as little as one tank full, may coat the catalyst element and render the converter useless.
- **Silicone** from sealants (RTV, etc.) or engine coolant that has leaked into the exhaust, may also coat the catalyst and render it useless.

There are other external factors that can cause the converter to degrade and require replacement. **Thermal shock** occurs when a hot converter is quickly exposed to cold temperature (snow, cold fuel, etc.), causing it to physically distort and eventually disintegrate. Converters that have sustained **physical damage** (seam cracks, shell puncture, etc.) should also be replaced as necessary.

EMISSION SUB SYSTEMS - Catalytic Converter

TWC Functional Checks

Before a converter is condemned and replaced, it is crucial that any problem(s) that may have contributed to the damage and failure of the converter is identified and repaired. If not, the replacement converter will soon fail!

Also, in order to accurately check catalytic converters, all engine mechanical, engine control systems, and emission sub-systems must be in proper working order or your results will be inaccurate. Remember, the converter relies on a narrow feed gas margin or efficiency suffers.

There are a number of tests that can be performed on catalytic converters; however, no one test should be used to verify the complete integrity and conversion efficiency of the converter. The following are examples of typical TWC checks.

Visual Inspection

The first check, and the easiest, is to perform a thorough visual inspection of the converter and related hardware. Many converter problems have obvious symptoms that are easily identified during a visual inspection. Look for the following; pinched exhaust pipe, physical damage to the insulator or converter shell, cracked or broken seams, excessive rust damage, mud or ice in the tailpipe, etc.

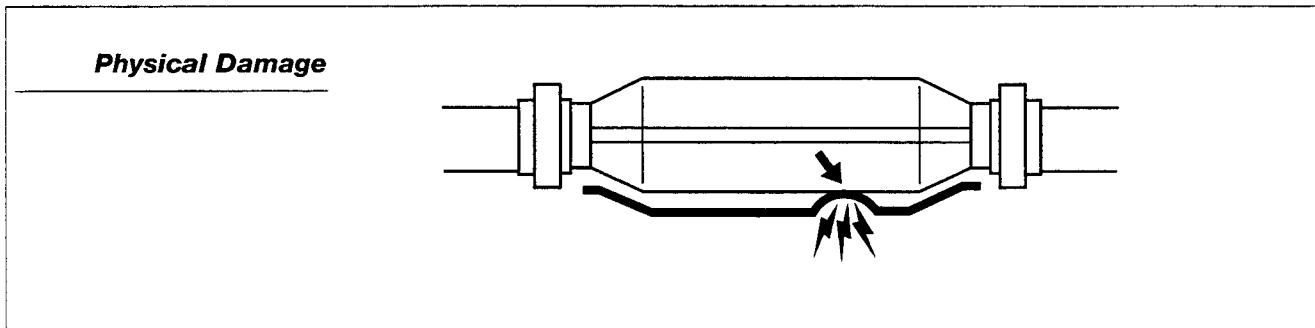

Rattle Test

Perform a rattle test by firmly hitting the converter shell with the center of your palm (avoid hitting it too hard or you may damage it!) If the substrate is OK it should sound solid. If it rattles, the substrate has disintegrated and the converter should be replaced.

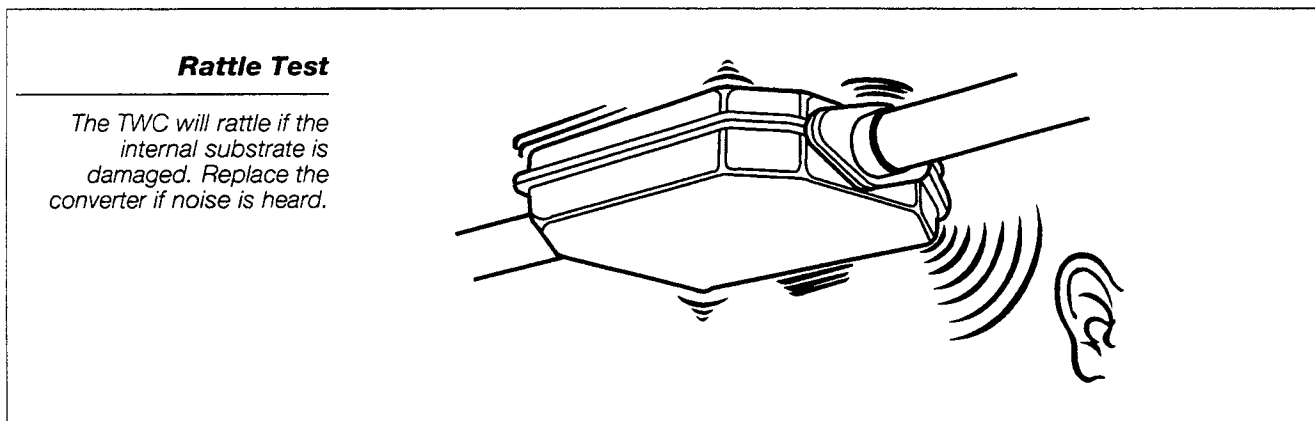

Restricted Exhaust System Check

Driveability comments like "lacks power under load" or "difficult to start, acts flooded and also lacks power" may indicate a restricted exhaust. In extreme cases the exhaust may be so restrictive that the engine will not start. Generally speaking, here's how to test for a restricted exhaust system:

- Attach a vacuum gauge to an intake manifold vacuum source.
- Allow the engine to reach operating temperature.
- From idle, raise engine speed to approximately 2000 rpm.
- Note: The vacuum reading should be close to normal idle reading.
- Next, quickly release the throttle.

Note: The vacuum reading should momentarily rise then smoothly drop back to a normal idle reading. If the vacuum rises slowly or does not quickly return to normal level, the exhaust system may be restricted.

If the catalyst has disintegrated, it is likely that contamination has also restricted the muffler. Don't overlook that possibility. If the engine will not start, try disconnecting the exhaust system at the manifold and see if the engine will start.

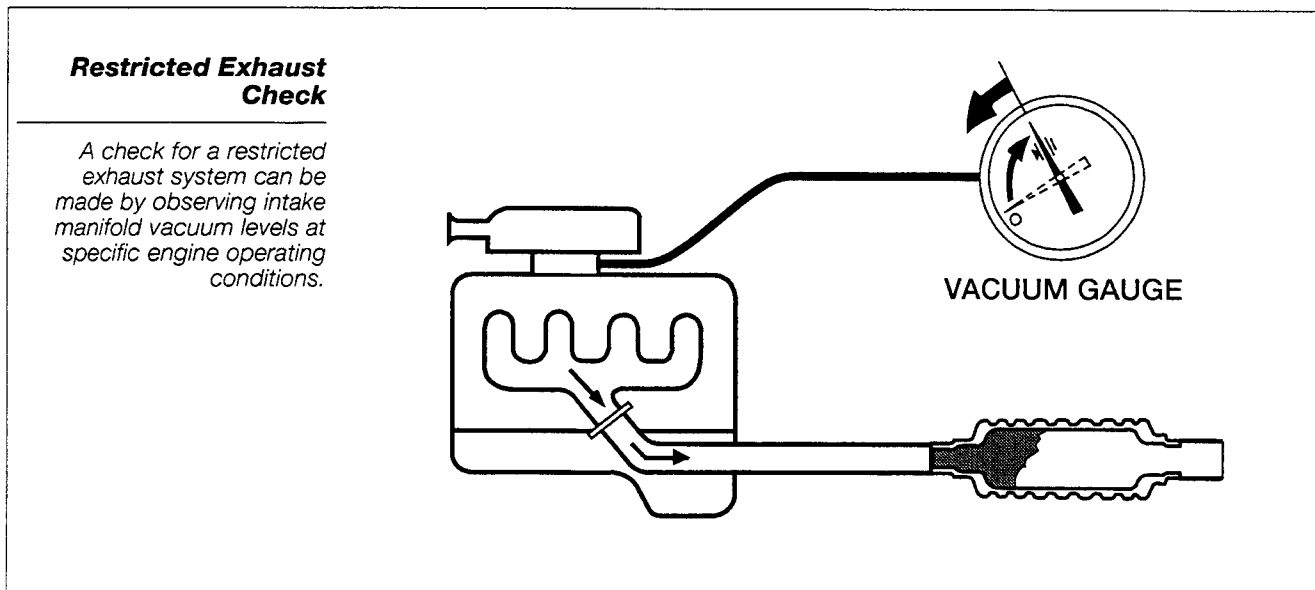

Lead Contamination Check

A common cause of converter contamination is lead poisoning. As mentioned, lead reduces converter efficiency by coating the catalyst element. Special lead detecting test paper (or paste) is available from aftermarket suppliers that checks for the presence of lead in the tailpipe. Follow the specific instructions provided by the test paper manufacturer.

TWC Efficiency Quick Check (CA Vehicles)

On CA vehicles equipped with sub-O₂ sensors, a quick check of TWC operation can be made by comparing the signal activity of the main oxygen sensor with the sub-oxygen sensor. Since the main O₂S is located upstream of the converter and the sub-O₂S is located downstream, a signal comparison would indicate whether a catalytic reaction is taking place inside the converter. If the catalyst is operating, the main O₂S signal should normally toggle rich/lean, while the sub-O₂ sensor should react very slowly (similar to a bad main O₂S signal.) Main and sub O₂S signals can be observed using the graphing display of the Diagnostic Tester (OBD-II) or V-BoB on other models.

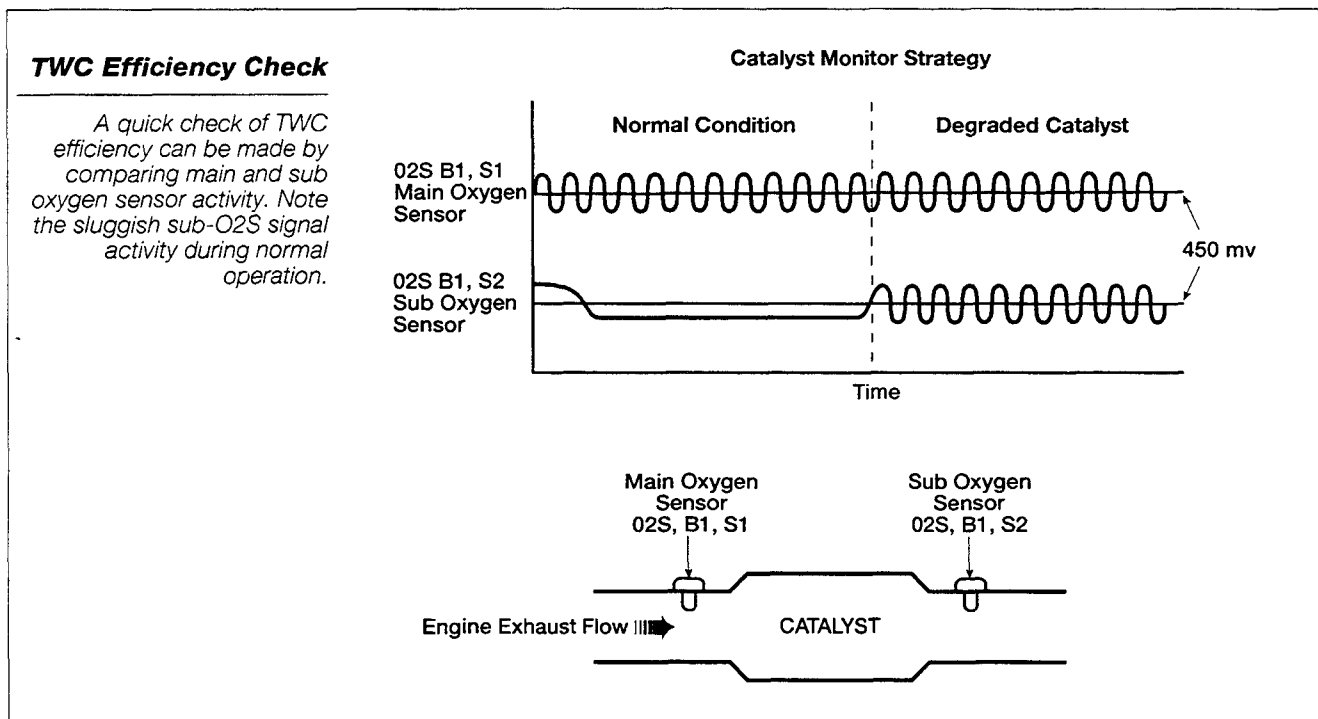

NOTE: Before any catalyst efficiency tests are performed, it is important that both the engine and converter are properly preconditioned. Remember, proper feed gas conversion cannot take place until the closed loop control system is actively maintaining ideal mixture and the catalyst has reached operating temperature. To ensure these conditions are met, particularly during cold ambient conditions, operate the engine off-idle until the TWC is sufficiently heated. This will ensure optimal catalyst conversion efficiency.